

CUSTOMER :

SPEC NO.:	D-0601-010-E
DATE :	Nov.27, 2019

RoHS Compliant

SPECIFICATIONS

Product Description : Wire Wound Chip Inductor

Part Number : SWI0402CT SERIES

Customer Part Number : _____

[For Customer Approval Only]

Date :

Approved By	Verified By	Rechecked By	Checked By

Approved By	Verified By	Prepared By
ISKANDAR NG	KM LEE	RABIATUL



FACTORY:
AOBA TECHNOLOGY (M) SDN. BHD.
No.5, Jalan BS 7/7, Off Jalan Cempaka, Seksyen 9,
Taman Bukit Serdang, 43300 Seri Kembangan,
Selangor, Malaysia.
Tel : 603-89422111 Fax : 603-89425888

HEAD QUARTERS:
ABC TAIWAN ELECTRONICS CORP.
No.98, Ln.298, Huandong Rd.,
Yangmei 32665 Taoyuan, Taiwan
Tel: 886-3-478-8188
Fax: 886-3-475-5503

WIRE WOUND CHIP INDUCTORS SWI0402CT SERIES

Introductions

The SWI series are wire wound chip inductors widely used in the communication applications such as cellular phones, cable modem, ADSL, repeaters, Bluetooth, and other electronic devices.

The wire wound inductors advance in higher self resonate frequency, better Q factor, and much more stable performance. Precious tolerance of 2% is available.

Features

- * Operating temperature -40 to +125°C.
- * Excellent solderability and resistance to soldering heat.
- * Suitable for reflow soldering.
- * High reliability and easy surface mount assembly.
- * Wide range of inductance values are available for flexible needs.

Part Number Code

SWI 0402 C T 3N9 J - □□

1 2 3 taping 4 5 6

1 Product Type

2 Chip Dimension

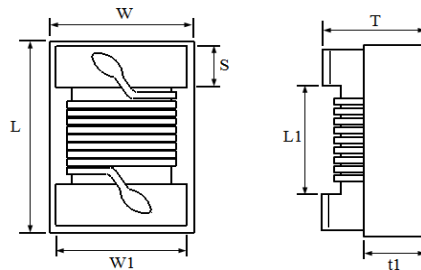

Size (inch) mm	Length (L) (inch) mm	Width (W) (inch) mm	Thickness (T) (inch) mm	Terminal (S) (inch) mm	L1 (Ref.) mm	W1 (Ref.) mm	(t1) (Ref.) mm
SWI 0402 1005	(0.039 ± 0.004) 1.00 ± 0.10	(0.022 ± 0.004) 0.55 ± 0.10	(0.020 ± 0.004) 0.50 ± 0.10	(0.008 ± 0.004) 0.20 ± 0.10	0.60	0.48	0.20

3 Material Type

C : Ceramic Material

4 Inductance Value

3N9 = 3.9nH 39N = 39nH R12 = 120nH

5 Tolerance

B = ±0.20 nH G = ±2% K = ±10%
S = ±0.30 nH J = ±5%

6 Internal Code

If any

CHIP INDUCTOR SPECIFICATIONS

1. Scope

This specification applies to fixed inductors of the following types used in electronic equipment.

Ceramic Type : For lower inductance with high Q factor at high frequency and stable circuit requirement.

2. Construction

Configuration

& Dimension : Please refer to the attached figures and tables.

Terminals : The terminals shall consist of Mo/Mn alloy followed by Nickel, then Gold for easier soldering.

3. Operating Temperature Range

Operating Temperature Range is the scope of ambient temperature at which the inductor can be operated continuously at rated current.

Temp. Range : -40°C to +125°C

4. Ingredient of terminals electrode

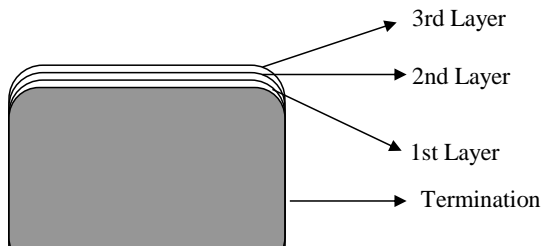

- a) 1st layer : Mo/Mn
- b) 2nd layer : Ni
- c) 3rd layer : Au

5. Characteristics

Standard Atmospheric Conditions

Unless otherwise specified, the standard range of atmospheric conditions for making measurements and tests are as follows :

Ambient Temperature : 25°C ± 2°C

Relative Humidity : 60% to 70%

Air Pressure : 86 kPa to 106 kPa

CHIP INDUCTOR SPECIFICATIONS

Temperature profile

- a. Reflow temperature profile
(Temperature of the mounted parts surface on the printed circuit board)

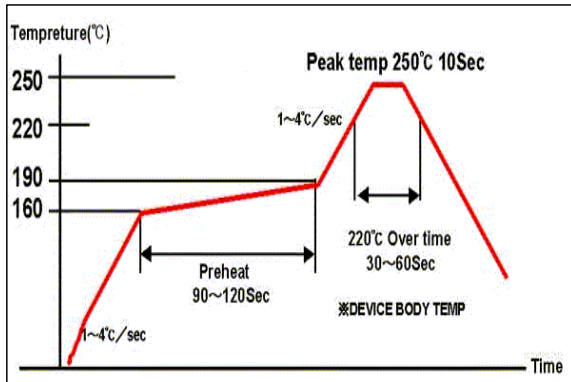

Recommended Peak Temperature : 250°C Max
 250°C up /within 10secs
 Max. Reflow temperature : 260°C.
 Gradient of temperature rise : av 1-4°C/sec
 Preheat : 160-190°C/within 90-120secs
 220°C up /within 30-60secs
 Composition of solder Sn-3Ag-0.5Cu

- b. Dip temperature

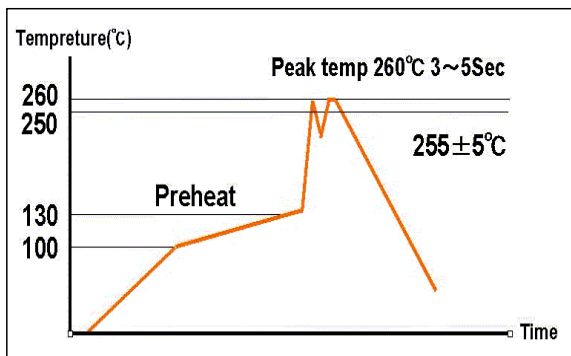

Solder bathtub temperature: 260°C max.
 within 5secs.
 Preheating temperature: 100~130°C
 deposit solder temperature.
 Composition of solder Sn-3Ag-0.5Cu

- c. Soldering iron tip temperature : 350°C max / within 3 seconds.

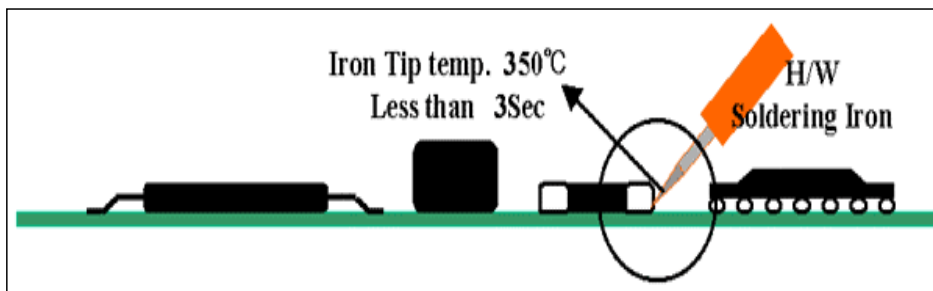

**CHIP INDUCTOR
WIRE WOUND TYPE**

SWI 0402 (1005) CERAMIC SERIES

Specification

Part No.	Inductance ¹ (nH)	Percent Tolerance	Q ²		S.R.F. ³ Min (MHz)	RDC ⁴ Max (Ω)	IDC ⁵ Max (mA)
			Min ²	Typical @900MHz			
SWI0402CT1N0 □-□□	1.0 @ 250 MHz	B, S	13	26	6000	0.045	1360
SWI0402CT1N2 □-□□	1.2 @ 250 MHz	B, S	13	23	6000	0.060	1360
SWI0402CT1N5 □-□□	1.5 @ 250 MHz	B, S	16	29	6000	0.070	1040
SWI0402CT1N8 □-□□	1.8 @ 250 MHz	B, S	16	29	6000	0.070	1040
SWI0402CT1N9 □-□□	1.9 @ 250 MHz	B, S	16	29	6000	0.070	1040
SWI0402CT2N0 □-□□	2.0 @ 250 MHz	B, S, J	16	30	6000	0.070	1040
SWI0402CT2N2 □-□□	2.2 @ 250 MHz	B, S	18	32	6000	0.070	960
SWI0402CT2N4 □-□□	2.4 @ 250 MHz	B, S	16	35	6000	0.068	790
SWI0402CT2N7 □-□□	2.7 @ 250 MHz	B, S	16	31	6000	0.120	860
SWI0402CT3N3 □-□□	3.3 @ 250 MHz	K, J, B	20	41	6000	0.066	840
SWI0402CT3N6 □-□□	3.6 @ 250 MHz	K, J, B	20	43	6000	0.066	840
SWI0402CT3N9 □-□□	3.9 @ 250 MHz	K, J, B	20	41	5800	0.066	840
SWI0402CT4N3 □-□□	4.3 @ 250 MHz	K, J, B	18	45	6000	0.091	700
SWI0402CT4N7 □-□□	4.7 @ 250 MHz	K, J, B	15	45	4775	0.130	640
SWI0402CT5N1 □-□□	5.1 @ 250 MHz	K, J, B	23	49	5800	0.083	800
SWI0402CT5N6 □-□□	5.6 @ 250 MHz	K, J, B	23	46	5800	0.083	760
SWI0402CT6N2 □-□□	6.2 @ 250 MHz	K, J, B	23	49	5800	0.083	760
SWI0402CT6N8 □-□□	6.8 @ 250 MHz	K, J, B	20	50	4800	0.083	680
SWI0402CT7N5 □-□□	7.5 @ 250 MHz	K, J, B	25	50	5800	0.104	680
SWI0402CT8N2 □-□□	8.2 @ 250 MHz	K, J, B	25	49	4400	0.104	680
SWI0402CT8N7 □-□□	8.7 @ 250 MHz	K, J, B	18	50	4100	0.200	480
SWI0402CT9N0 □-□□	9.0 @ 250 MHz	K, J, B	25	49	4160	0.104	680
SWI0402CT9N5 □-□□	9.5 @ 250 MHz	K, J, B	18	45	4000	0.200	680
SWI0402CT10N □-□□	10 @ 250 MHz	K, J, G	23	47	3900	0.195	480
SWI0402CT11N □-□□	11 @ 250 MHz	K, J, G	26	56	3680	0.120	640
SWI0402CT12N □-□□	12 @ 250 MHz	K, J, G	26	51	3600	0.120	640
SWI0402CT13N □-□□	13 @ 250 MHz	K, J, G	24	54	3450	0.210	560
SWI0402CT15N □-□□	15 @ 250 MHz	K, J, G	26	54	3280	0.172	560
SWI0402CT16N □-□□	16 @ 250 MHz	K, J, G	24	54	3100	0.220	560
SWI0402CT18N □-□□	18 @ 250 MHz	K, J, G	25	52	3100	0.230	520
SWI0402CT19N □-□□	19 @ 250 MHz	K, J, G	26	50	3040	0.202	480
SWI0402CT20N □-□□	20 @ 250 MHz	K, J, G	25	51	3000	0.250	420
SWI0402CT22N □-□□	22 @ 250 MHz	K, J, G	25	52	2800	0.300	400
SWI0402CT23N □-□□	23 @ 250 MHz	K, J, G	26	53	2720	0.214	400
SWI0402CT24N □-□□	24 @ 250 MHz	K, J, G	25	51	2700	0.300	400
SWI0402CT27N □-□□	27 @ 250 MHz	K, J, G	26	48	2480	0.298	400
SWI0402CT30N □-□□	30 @ 250 MHz	K, J, G	25	46	2350	0.300	400
SWI0402CT33N □-□□	33 @ 250 MHz	K, J, G	24	48	2350	0.350	400
SWI0402CT36N □-□□	36 @ 250 MHz	K, J, G	26	48	2320	0.403	320
SWI0402CT39N □-□□	39 @ 250 MHz	K, J, G	25	45	2100	0.550	320
SWI0402CT40N □-□□	40 @ 250 MHz	K, J, G	26	48	2240	0.438	320
SWI0402CT43N □-□□	43 @ 250 MHz	K, J, G	25	46	2030	0.810	240
SWI0402CT47N □-□□	47 @ 200 MHz	K, J, G	26	46	2100	0.830	210
SWI0402CT51N □-□□	51 @ 200 MHz	K, J	25	40	1750	0.820	210
SWI0402CT56N □-□□	56 @ 200 MHz	K, J	22	42	1760	0.970	200
SWI0402CT68N □-□□	68 @ 200 MHz	K, J	22	36	1620	1.120	180
SWI0402CT75N □-□□	75 @ 150 MHz	K, J	20	33	1550	1.200	160
SWI0402CT82N □-□□	82 @ 150 MHz	K, J	20	33	1500	1.250	150
SWI0402CT91N □-□□	91 @ 150 MHz	K, J	20	30	1350	2.300	120
SWI0402CTR10 □-□□	100 @ 150 MHz	K, J	20	30	1300	2.520	120
SWI0402CTR12 □-□□	120 @ 150 MHz	K, J	20	29	1100	2.660	110

- Inductance is measured in HP-4287A RF LCR meter with HP-16193 fixture.
- Q is measured in HP-4287A RF LCR meter with HP-16193 fixture. Test frequency same as Inductance.

- SRF is measured in ENA E5071B network analyzer or equivalent.
- RDC is measured in HP-4338B milliohm meter or equivalent.
- For 15 °C Rise.

Remarks:

Unit weight = 0.0008g (for ref.)
Without marking on the top surface of the product.

CHIP INDUCTOR
WIRE WOUND TYPE

SWI0402 (1005) CERAMIC SERIES

Specification

L vs Freq Plot

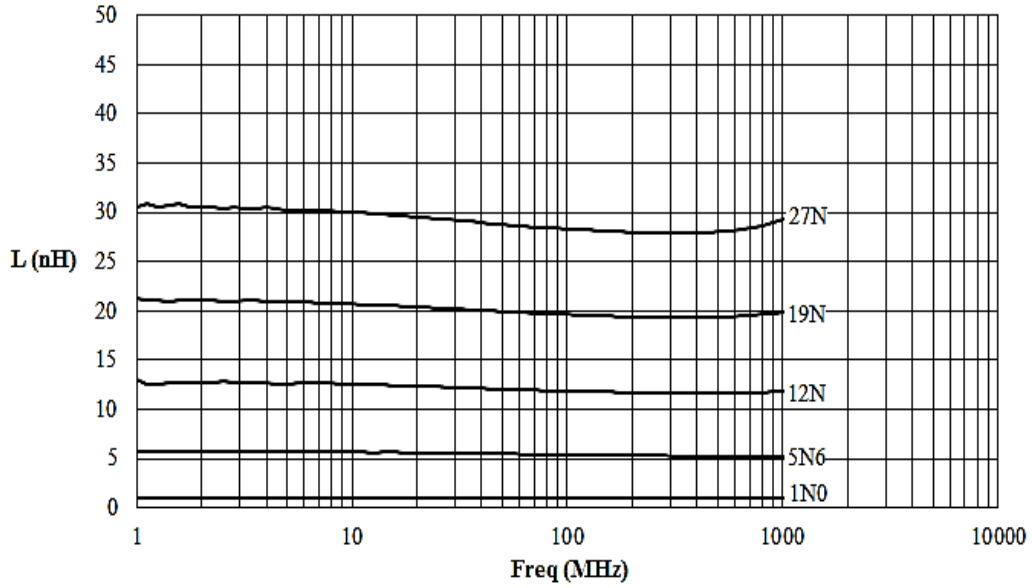

Q vs Freq Plot

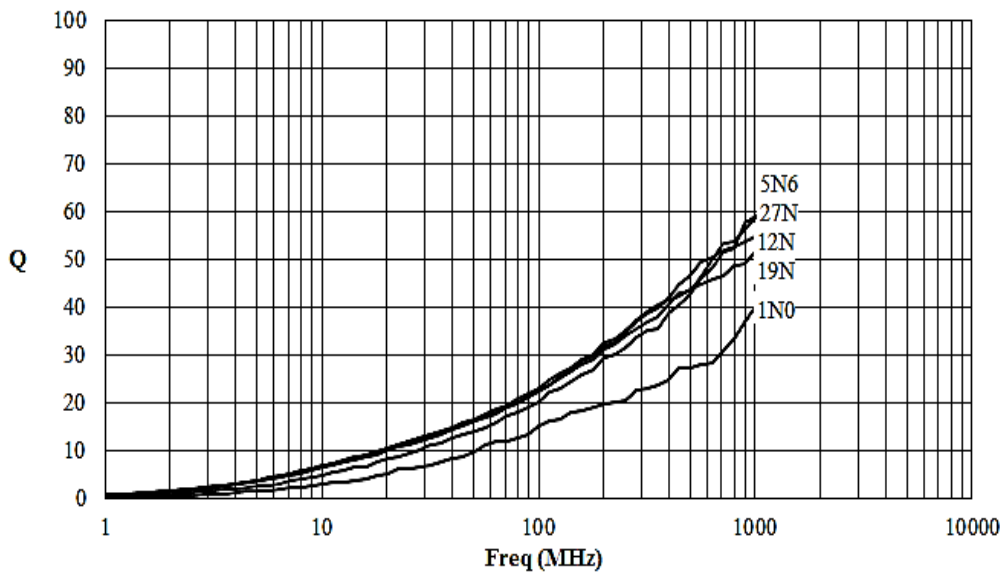

RELIABILITY TEST

ITEM		CONDITION	SPECIFICATION
Electrical Characteristics	Inductance and Tolerance	Measuring Frequency : As shown in Product Table Measuring Temperature : + 25 °C	Within Specified Tolerance
	Quality Factor		
	Insulation Resistance	Measured at 100V DC between inductor terminals and center of case.	1000 mega ohms minimum
	Dielectric Withstanding Voltage	Measured at 500V AC between inductor terminals and center of case for a maximum of 1 minute.	No damage occurs when the test voltage is applied.
	Temperature Coefficient of Inductance (TCL)	Over -40°C to +85°C at frequency specified in Product Table.	+ 25 to 500 ppm / °C $TCL = \frac{L1 - L2}{L1(T1-T2)} \times 10^6$ (ppm / °C)
Mechanical Characteristics	Component Adhesion (Push Test)	The component shall be reflow soldered onto a P. C. Board (240°C ± 5°C for 20 seconds). Then a dynamometer force gauge shall be applied to any side of the component.	0402 series ≥ 350g
	Drop Test	The inductor shall be dropped two times on the concrete floor or the vinyl tile from 1m naturally.	Change In Inductance: No more than 5% Change In Q: No more than 10%
	Thermal Shock Test	Each cycle shall consist of 30 minutes at -40°C followed by 30 minutes at +85°C with 5 minutes maximum transition time between temperature extremes. Test duration is 10 cycles.	Change In Appearance: Without distinct damage

RELIABILITY TEST

ITEM		CONDITION	SPECIFICATION
Endurance Characteristics	Solderability	Dip pads in flux and dip in solder pot containing lead free solder at $240\pm 5^{\circ}\text{C}$ for 5 seconds.	A minimum of 80% of the metalized area must be covered with solder.
	Resistance to Soldering Heat	Dip the components into flux and dip into solder pot containing lead free solder at $260\pm 5^{\circ}\text{C}$ for 5 ± 2 seconds.	Change In Inductance: No more than 5%
	Vibration (Random)	Inductors shall be randomly vibrated at amplitude of 1.5mm and frequency of 10 - 55 Hz: 0.04 G / Hz for a minimum of 15 minutes per axis for each of the three axes.	Change In Q: No more than 10%
	Cold Temperature Storage	Inductors shall be stored at temperature of $-40^{\circ}\text{C} \pm 2^{\circ}\text{C}$ for 1000 hours (+48 -0h). Then inductors shall be subjected to standard atmospheric conditions for 1 hour. After that, measurement shall be made.	Change In Appearance : Without distinct damage
	High Temperature Storage	Inductors shall be stored at temperature of $85^{\circ}\text{C} \pm 2^{\circ}\text{C}$ for 1000 hours (+48 -0h). Then inductors shall be subjected to standard atmospheric conditions for 1 hour. After that, measurement shall be made.	
	Moisture Resistance	Inductors shall be stored in the chamber at 45°C at 90-95 R.H. for 1000 hours. Then inductors are to be tested after 2 hours at room temperature.	Inductors shall not have a shorted or open winding.
	High Temperature with Loaded	Inductors shall be stored in the chamber at 85°C for 1000 hours with rated current applied. Inductors shall be tested at the beginning of the test at 500 hours and 1000 hours. Then inductors are to be tested after 1 hour at room temperature.	

PACKING INFORMATION

Packing Quantity

Type	Pcs / Reel
SWI0402	10,000

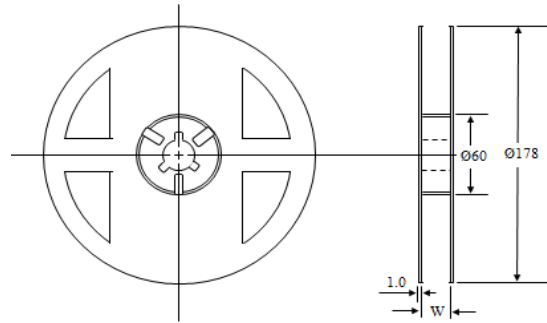

Dimensions (unit : mm)

Type	Chip Cavity		Insert Pitch	Tape Thickness	
	A	B	F	K	T
SWI0402	0.74	1.23	2.00	0.60	0.70

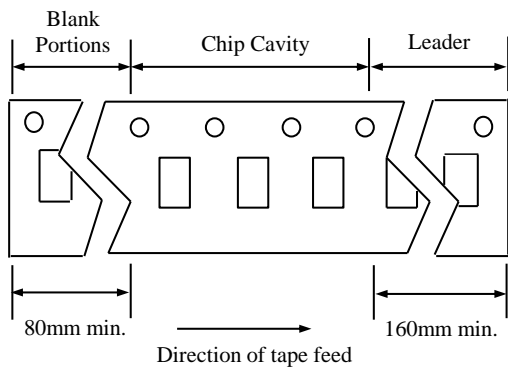
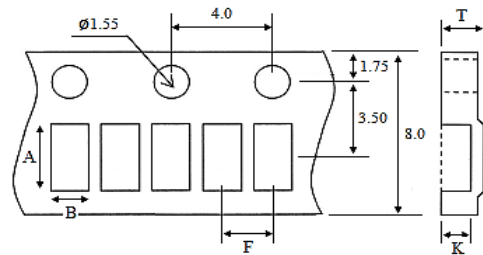

Top Tape Strength

The top tape requires a peel-off force of 0.2 to 0.7N in the direction of the arrow as illustrated below.

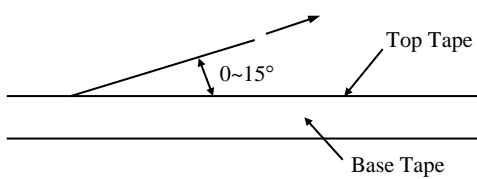

Recommended Pattern

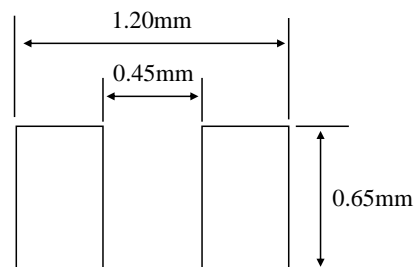

SAFETY NOTES & PRECAUTION

1. Products may not be used in applications that directly affect the personal safety or cause significant impacts and losses to society. If you apply to these applications, please be sure to contact us at first to confirm.
2. The storage period is less than 12 months. Ensure to follow the storage conditions (Temperature: 5 to 30°C, Humidity: 10 to 60% RH or less). If the storage period is exceeded the limit, the electrodes might be deteriorate/oxidized and affect soldering. Solderability should be checked if this period is exceeded.
Other storage precaution:
 - a) Products should be stored on the pallet for the prevention of the influence from humidity, dust and so on.
 - b) Products should be stored in the warehouse without heat shock, vibration, direct sunlight and so on.
 - c) Do not unpack the minimum package until immediately before use. After unpacking, re-seal promptly or store in deciccator with a desiccant.
 - d) Do not store product in bulk to prevent coils and parts being damaged.
3. Do not use or store in locations where there are corrosive gases (salt, acid, alkali, etc.).
4. Soldering condition for mounting should be within the specification range.
If overheated, a short circuit, performance deterioration, or lifespan shortening may occur.
5. When using, try to avoid excessive mechanical impact on the product such as collision / drop...etc.
6. When assembling a printed circuit board with a new mounted chip, be careful to avoid assembly deformation of the circuit board that may cause the overall or partial distortion of the circuit board such as at screw tightening position.
7. Self heating (temperature increase) occurs when the power is turned ON, so the tolerance should be sufficient for the thermal design.
8. Do not expose the products to magnets or magnetic fields.
9. If you would like to use this products for more stringent safety or reliability of performance and/or quality requirements, or its failure, malfunction or trouble may cause serious damage to society, individuals or property, or you have special requirement beyond the specification or condition in the catalogue, please contact us.
10. PCB should be designed so that products are not subjected to the mechanical stress caused by warping of the board as shown below. Bending and twisting of PCB will cause excessive mechanical stress and lead to crack in the product as well.

Products should be located in the sideways direction
(Length: a<b) to the mechanical stress.



11. Cleaning brush shall not touch the winding portion of the product to prevent the breaking of wire. Cleaning could cause failure and degradation of a product.
12. Care should be taken when transporting or handling product to avoid excessive vibration or mechanical shock. Product could be damaged by external mechanical pressure, stacked under heavy object, as well as strong shaking and drop.